



## Z3C2R-001

C-face Mount - Frame 56C

Suitable for pulley output

### Clutch Engagement/Brake Engagement

Air/Air

### Facing Type (Clutch & Brake)

High Coefficient

### Clutch Torque @ 80 PSI (max) – Dynamic

111 Pound Inches

### Brake Torque @ 80 PSI (max) – Dynamic

111 Pound Inches

### Maximum RPM

1,750

### Input Bore/Output Shaft

0.625 Inches

### Air Volume New (Clutch & Brake)

0.17 Cubic Inches

### Air Volume Worn (Clutch & Brake)

0.49 Cubic Inches

### Finish

Aluminum

### Overhung Load Capacity

93 Pounds

### Open or Enclosed Construction

Open

### Shipping Weight

8 Pounds

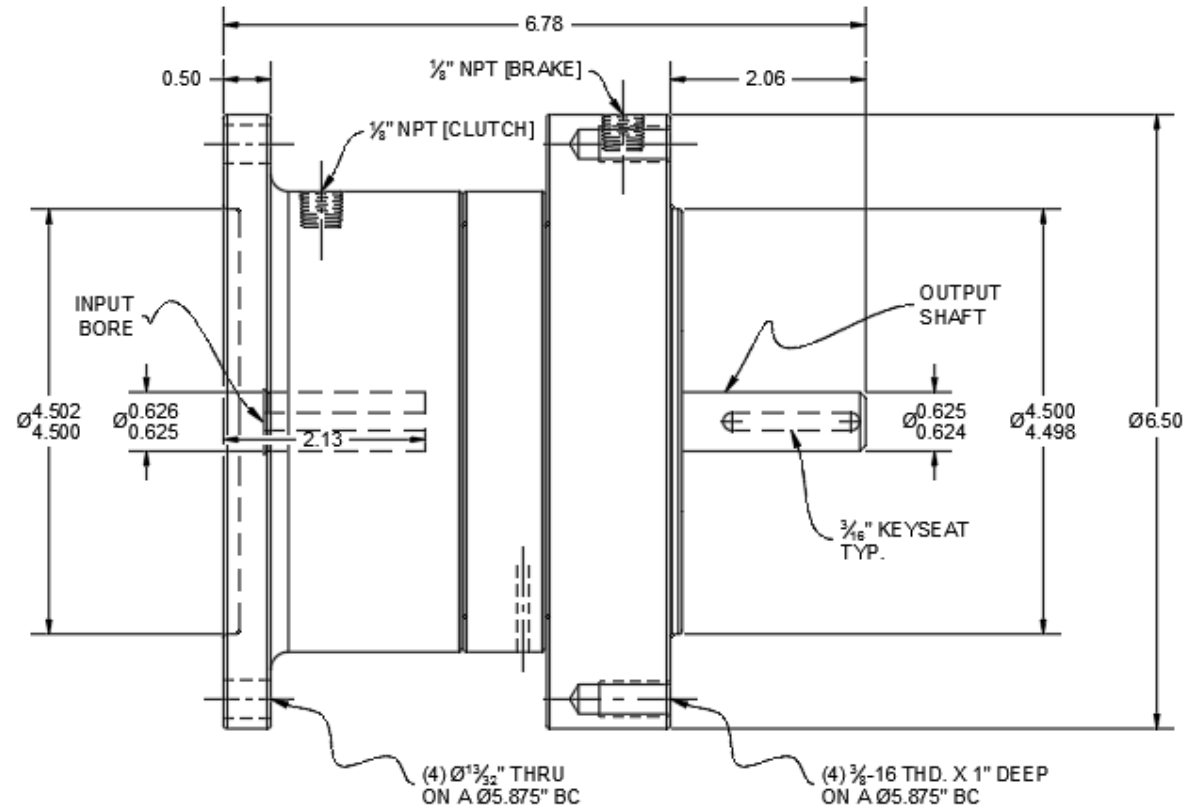

### TORQUE vs. AIR PRESSURE

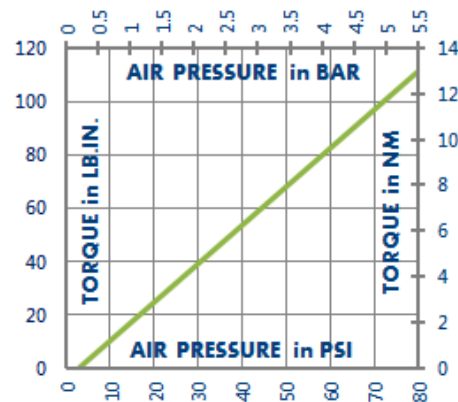

### NEW vs. BURNISHED TORQUE

New clutch or brake torque is approximately 40% less than rated design torque until the friction and drive discs are worn in (lapped, burnished). The length of time for wear-in to occur varies by application.

When calculating required torque always use a service factor of 1.5 to 2. It is not recommended to select a product for use at its maximum rated torque for continuous duty.

### PRODUCT SELECTION

Torque capacity is only one factor to consider when making a product selection. Insure that you will have right product for the job by contacting our engineering department for application review and selection assistance.



859-291-0849

engineering@machiii.com

www.machiii.com

# Z3C2R-001

## Parts Diagram

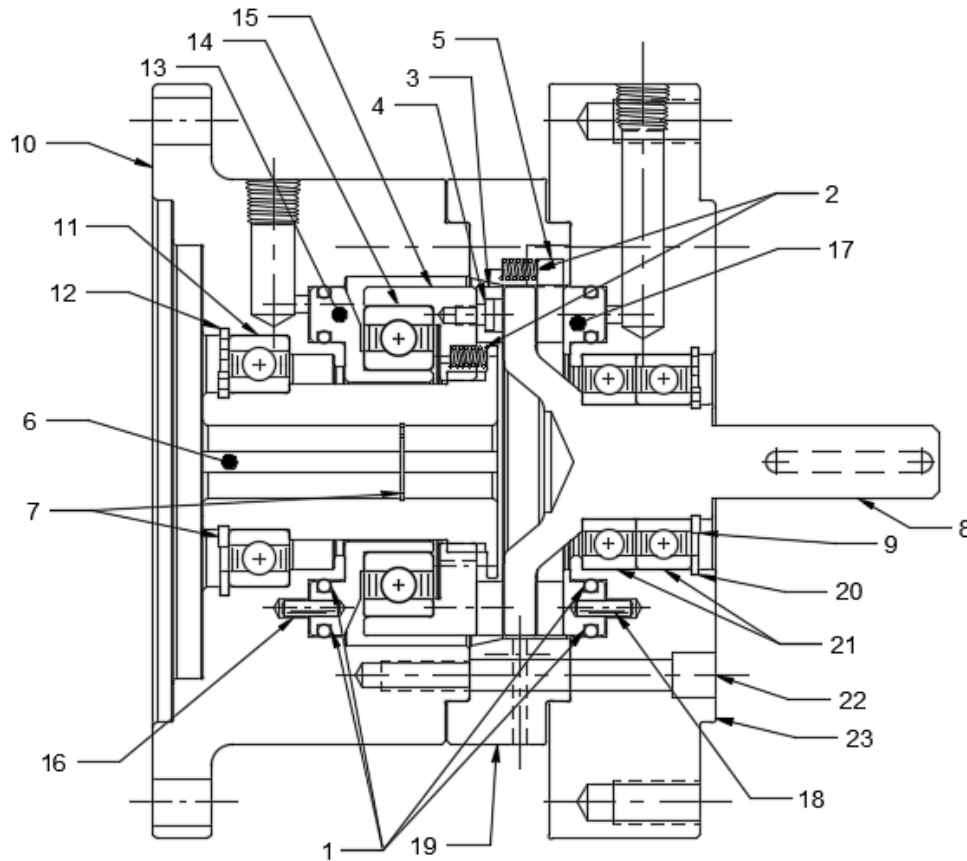

REF#	DESCRIPTION & PARTS INCLUDED	QUANTITY	KIT NUMBER
<b>REPAIR KIT</b>			<b>Z3C2R-001-RPRK</b>
1	O-Ring	4	
2	Coil Spring	6	
3	Friction Disc (Clutch)	1	
4	Screw	3	
5	Friction Disc (Brake)	1	
<b>DRIVE HUB KIT</b>			<b>Z3C2R-001-HUBK</b>
6	Drive Hub	1	
7	Retainer Ring	2	
<b>MALE HUB KIT</b>			<b>Z3C2R-001-MHBK</b>
8	Male Hub	1	
9	Retainer Ring	1	
<b>CYLINDER KIT</b>			<b>Z3C2R-001-CYLK</b>
10	Cylinder	1	
11	Bearing	1	
12	Retainer Ring	1	
<b>PISTON KIT - CLUTCH</b>			<b>Z3C2R-001-PSCK</b>
13	Cone	1	
14	Bearing	1	
15	Drive Disc	1	
16	Pin	2	
<b>PISTON KIT - BRAKE</b>			<b>Z3C2R-001-PSBK</b>
17	Piston	1	
18	Pin	2	
19	SPACER	1	Z3C2R-001-P027
<b>MALE ADAPTER KIT</b>			<b>Z3C2R-001-MADK</b>
20	Retainer Ring	1	
21	Bearing	2	
22	Screw	3	
23	Adapter Male	1	

### PARTS KITS

The *Repair Kit* contains common wear items for this product. Users are encouraged to stock one or more repair kits considering the number of units installed and the potential downtime if machinery on which the unit is installed is critical equipment. To obtain current pricing and lead time for parts kits, contact customer service.

[orders@machiii.com](mailto:orders@machiii.com)

### ADDITIONAL PRODUCT INFORMATION

Click on the links below or copy and paste into your web browser.

To view the Installation & Maintenance Manual for this product:

[http://www.machiii.com/PDF/Product-Manuals/CLUTCHBR\\_AIR\\_SHAFT\\_BALLBRG\\_MANUAL.pdf](http://www.machiii.com/PDF/Product-Manuals/CLUTCHBR_AIR_SHAFT_BALLBRG_MANUAL.pdf)

For information about the application and use of this and other Mach III products:

<http://machiii.com/Application/Default.asp>



859-291-0849

[engineering@machiii.com](mailto:engineering@machiii.com)

[www.machiii.com](http://www.machiii.com)