



V6R1G-001

Torque Limiter Mechanism with Adapter

Momentary Overload Protection

Mechanism DOES NOT support Adapter

Engagement/Disengagement

Spring/None

Facing Type

Low Coefficient

Minimum Torque Setting

310 Pound Inches

Maximum Torque Setting (Spring Compression ≈ 17%)

3,070 Pound Inches

Maximum RPM

1,750

Bore with Standard Keyway

50 mm [1.969 inches]

Finish

Aluminum

Open or Enclosed Construction

Open

Component Mounting Bolt Circle

5.375 Inches

Shipping Weight

18 Pounds

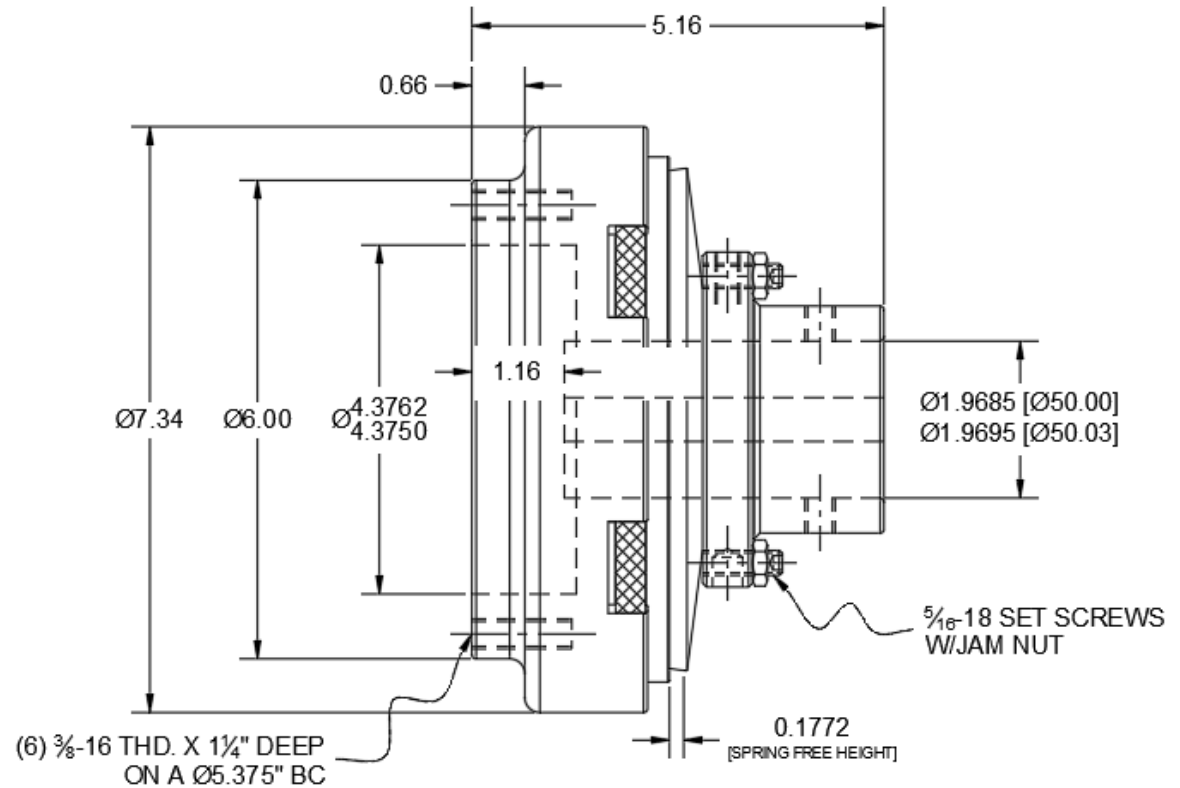

TORQUE vs. SPRING PRESSURE

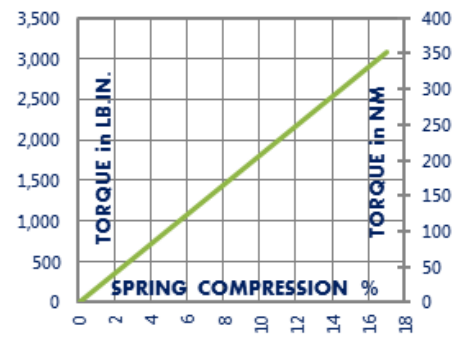

NEW vs. BURNISHED TORQUE

New clutch or brake torque is approximately 40% less than rated design torque until the friction and drive discs are worn in (lapped, burnished). The length of time for wear-in to occur varies by application.

When calculating required torque always use a service factor of 1.5 to 2. It is not recommended to select a product for use at its maximum rated torque for continuous duty.

PRODUCT SELECTION

Torque capacity is only one factor to consider when making a product selection. Insure that you will have right product for the job by contacting our engineering department for application review and selection assistance.



859-291-0849

engineering@machiii.com

www.machiii.com

V6R1G-001

Parts Diagram

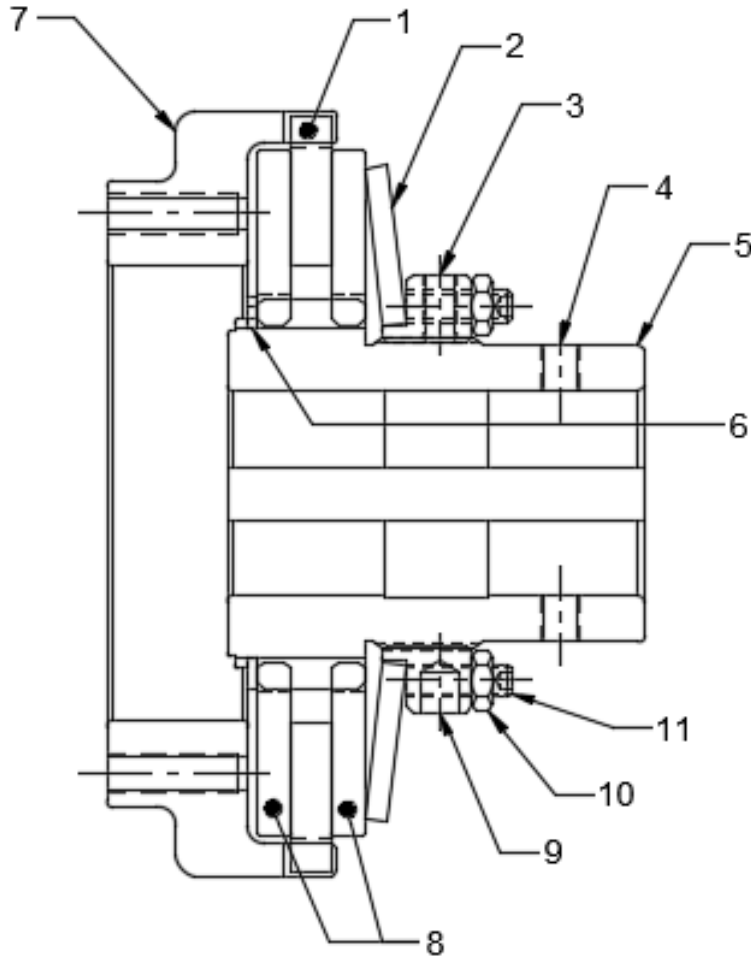

REF#	DESCRIPTION & PARTS INCLUDED	QUANTITY	KIT NUMBER
	REPAIR KIT		V6R1G-001-RPRK
1	Friction Disc	1	
2	Disc Spring	1	
3	Nylon Point Set Screw	1	
	DRIVE HUB KIT		V6R1G-001-HUBK
4	Set Screw	2	
5	Drive Hub	1	
6	Retainer Ring	1	
7	ADAPTER	1	V6G1G-STL-P046
	DRIVE DISC KIT		T6A1G-STH-DRDK
8	Drive Disc	2	
	FACING KIT		V6R1G-001-FCGK
1	Friction Disc	1	
3	Nylon Point Set Screw	1	
	NUT KIT		T6A1G-STL-NUTK
3	Nylon Point Set Screw	1	
9	Nut	1	
10	Jam Nut	6	
11	Oval Point Set Screw	6	

PARTS KITS

The *Repair Kit* contains common wear items for this product. Users are encouraged to stock one or more repair kits considering the number of units installed and the potential downtime if machinery on which the unit is installed is critical equipment. To obtain current pricing and lead time for parts kits, contact customer service.

orders@machiii.com

ADDITIONAL PRODUCT INFORMATION

Click on the links below or copy and paste into your web browser.

To view the Installation & Maintenance Manual for this product:

http://www.machiii.com/PDF/Product-Manuals/TORQLIM_MECH_W_ADAPT_MANUAL.pdf

For information about the application and use of this and other Mach III products:

<http://machiii.com/Application/Default.asp>



859-291-0849

engineering@machiii.com

www.machiii.com