



T3G1F-001

Torque Limiter with Square Input and Output

Momentary Overload Protection

Engagement/Disengagement	Spring/None
Facing Type	Low Coefficient
Minimum Torque Setting	40 Pound Inches
Maximum Torque Setting (Spring Compression ≈ 75%)	400 Pound Inches
Maximum RPM	1,750
Bore without Keyway	24 mm
Finish	Stainless Steel
Open or Enclosed Construction	Enclosed
Shipping Weight	4 Pounds

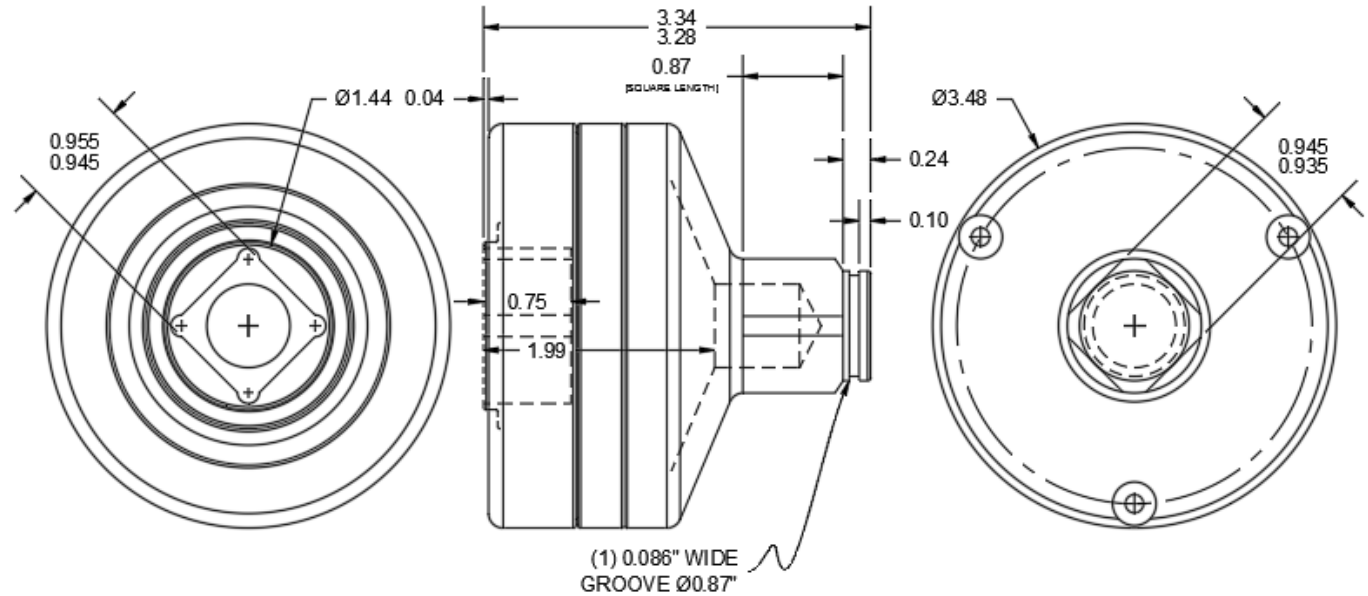

TORQUE vs. SPRING PRESSURE

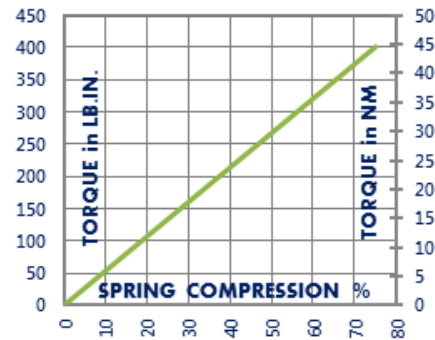

NEW vs. BURNISHED TORQUE

New clutch or brake torque is approximately 40% less than rated design torque until the friction and drive discs are worn in (lapped, burnished). The length of time for wear-in to occur varies by application.

When calculating required torque always use a service factor of 1.5 to 2. It is not recommended to select a product for use at its maximum rated torque for continuous duty.

PRODUCT SELECTION

Torque capacity is only one factor to consider when making a product selection. Insure that you will have right product for the job by contacting our engineering department for application review and selection assistance.



859-291-0849
 engineering@machiii.com
 www.machiii.com

T3G1F-001

Parts Diagram

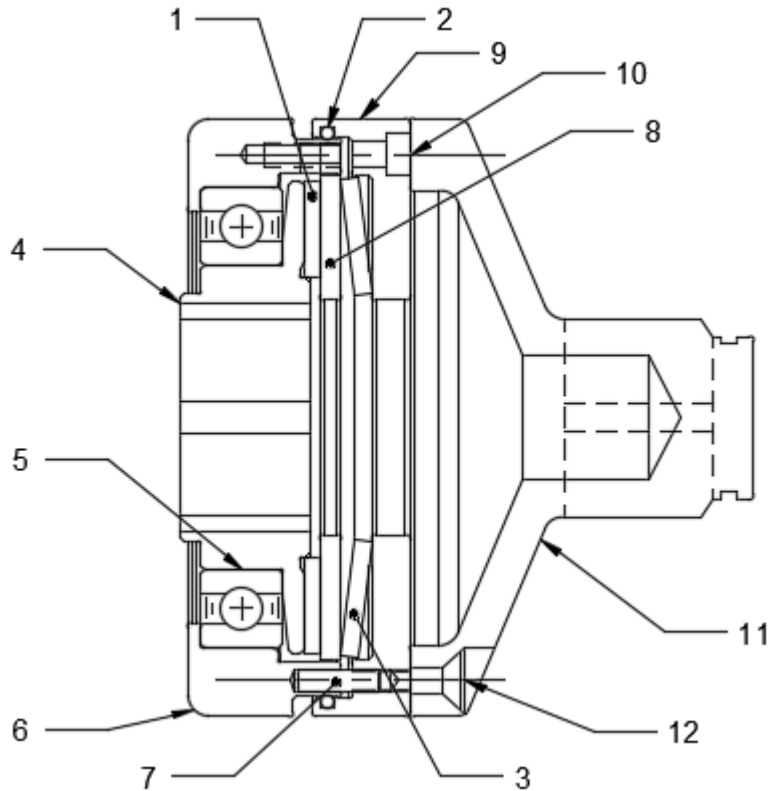

REF#	DESCRIPTION & PARTS INCLUDED	QUANTITY	KIT NUMBER
	REPAIR KIT		T3G1F-001-RPRK
1	Friction Disc	1	
2	O-Ring	1	
3	Disc Spring	1	
4	DRIVE HUB	1	T3G1F-001-P001
	SLEEVE KIT		T3G1F-001-SLVK
5	Bearing	1	
6	Sleeve	1	
7	Pin	4	
8	DRIVE DISC KIT	1	T3G1F-001-P005
	FACING KIT		T3G1F-001-FCGK
1	Friction Disc	1	
	COVER KIT		T3G1F-001-COVK
9	Cover	1	
10	Screw	3	
	COUPLING KIT		T3G1F-001-CPLK
11	Coupling	1	
12	Screw	3	

PARTS KITS

The *Repair Kit* contains common wear items for this product. Users are encouraged to stock one or more repair kits considering the number of units installed and the potential downtime if machinery on which the unit is installed is critical equipment. To obtain current pricing and lead time for parts kits, contact customer service.

orders@machiii.com

ADDITIONAL PRODUCT INFORMATION

Click on the links below or copy and paste into your web browser.

Contact Mach III Engineering for Installation & Maintenance Manual for this product:
engineering@machiii.com

For information about the application and use of this and other Mach III products:
<http://machiii.com/Application/Default.asp>



859-291-0849

engineering@machiii.com

www.machiii.com