



# D3B1Y-003

## Spring Engaged Brake

Shaft Mount

<b>Engagement/Disengagement</b>	Spring/Air
<b>Facing Type</b>	High Coefficient
<b>Torque – Dynamic</b>	139 Pound Inches
<b>Minimum Disengagement Pressure</b>	55 PSI
<b>Maximum Operating Pressure</b>	80 PSI
<b>Maximum RPM</b>	1,750
<b>Bore with Standard Keyway</b>	1.000 Inches
<b>Air Volume New</b>	0.06 Cubic Inches
<b>Air Volume Worn</b>	0.14 Cubic Inches
<b>Finish</b>	Aluminum
<b>Open or Enclosed Construction</b>	Open
<b>Mounting Bolt Circle</b>	3.687 Inches
<b>Shipping Weight</b>	3 Pounds

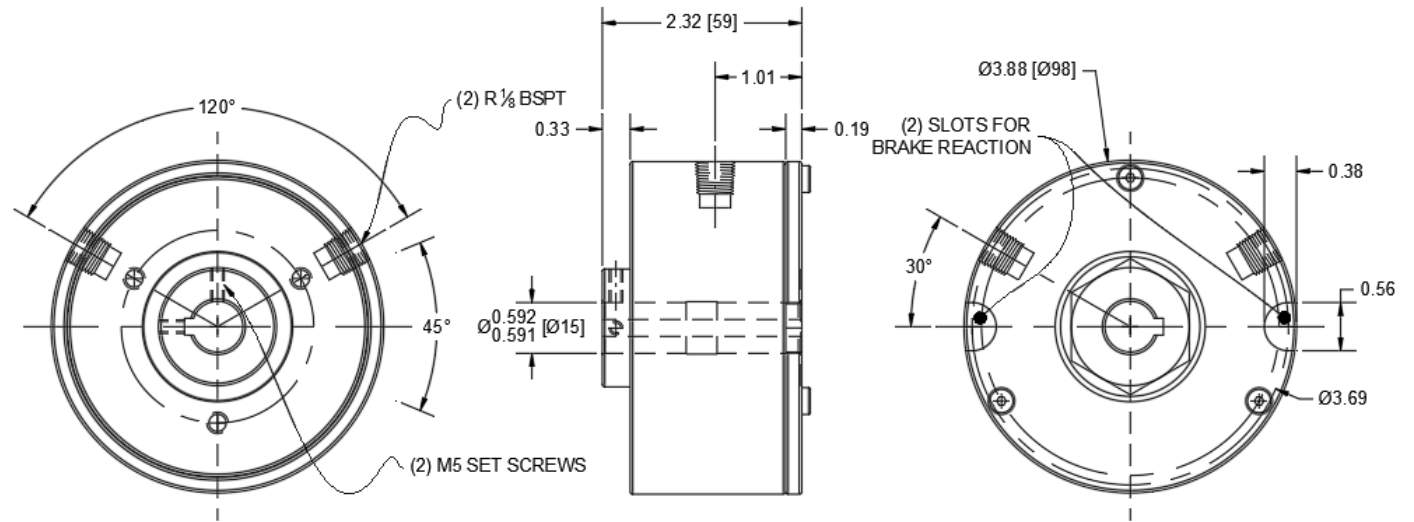

### TORQUE vs. SPRING PRESSURE

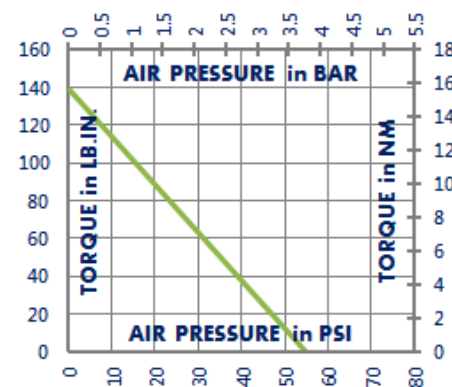

### NEW vs. BURNISHED TORQUE

New clutch or brake torque is approximately 40% less than rated design torque until the friction and drive discs are worn in (lapped, burnished). The length of time for wear-in to occur varies by application.

When calculating required torque always use a service factor of 1.5 to 2. It is not recommended to select a product for use at its maximum rated torque for continuous duty.

### PRODUCT SELECTION

Torque capacity is only one factor to consider when making a product selection. Insure that you will have right product for the job by contacting our engineering department for application review and selection assistance.



859-291-0849

engineering@machiii.com

www.machiii.com

# D3B1Y-003

## Parts Diagram

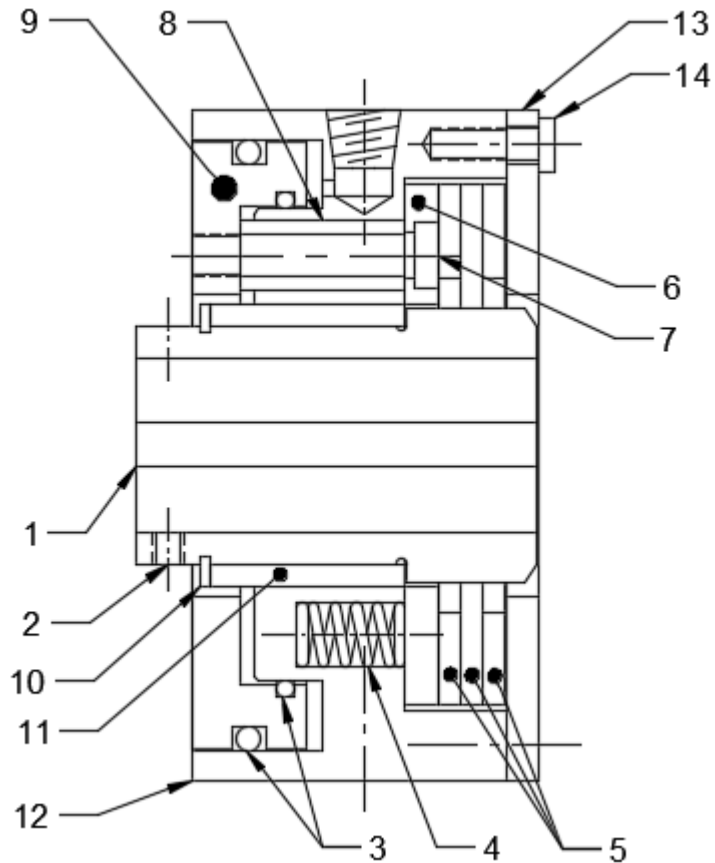

REF#	DESCRIPTION & PARTS INCLUDED	QUANTITY	KIT NUMBER
<b>DRIVE HUB KIT</b>			<b>D3B1Y-003-HUBK</b>
1	Drive Hub	1	
2	Set Screw	2	
<b>REPAIR KIT</b>			<b>D3B1Y-003-RPRK</b>
3	O-Ring	2	
4	Coil Spring	6	
5	BONDED FRICTION / DRIVE DISC	1	
<b>PISTON KIT</b>			<b>D3B1Y-003-PSTK</b>
6	Pressure Plate	1	
7	Screw	3	
8	Spacer	3	
9	Piston	1	
<b>CYLINDER KIT</b>			<b>D3B1Y-003-CYLK</b>
10	Retainer Ring	1	
11	Bushing	1	
12	Cylinder	1	
<b>COVER KIT</b>			<b>D3B1Y-003-COVK</b>
13	Cover	1	
14	Screw	3	
<b>FACING KIT</b>			<b>D3B1Y-003-FCGK</b>
15	BONDED FRICTION / DRIVE DISC	1	

### PARTS KITS

The *Repair Kit* contains common wear items for this product. Users are encouraged to stock one or more repair kits considering the number of units installed and the potential downtime if machinery on which the unit is installed is critical equipment. To obtain current pricing and lead time for parts kits, contact customer service.

[orders@machiii.com](mailto:orders@machiii.com)

### ADDITIONAL PRODUCT INFORMATION

Click on the links below or copy and paste into your web browser.

To view the Installation & Maintenance Manual for this product:

[http://www.machiii.com/PDF/Product-Manuals/BRAKES\\_FLANGE\\_SPRING\\_MANUAL.pdf](http://www.machiii.com/PDF/Product-Manuals/BRAKES_FLANGE_SPRING_MANUAL.pdf)

For information about the application and use of this and other Mach III products:

<http://machiii.com/Application/Default.asp>



859-291-0849

[engineering@machiii.com](mailto:engineering@machiii.com)

[www.machiii.com](http://www.machiii.com)