

# SensiFlex®

## Installation & Maintenance Instructions

# SENSIFLEX® FOOT MOUNT TENSION CONTROL CLUTCH

Patent No. 6,578,691 B1



### Catalog Products:

[38FM](#) & [38FM-ULOW](#)

[58FM](#) & [58FM-ULOW](#)

[78FM](#) & [78FM-ULOW](#)

[98FM](#) & [98FM-ULOW](#)

[118FM](#) & [118FM-ULOW](#)

*And non-catalog variations of this clutch design.*

CLICK on product numbers above to obtain the product detail sheet which includes dimensional data helpful during installation.

### Mach III Technical Support

Toll Free: 866-291-0849

International: 01-859-291-0849

Email: [engineering@machiii.com](mailto:engineering@machiii.com)

[www.machiii.com](http://www.machiii.com)

Spec sheets and 3D models are available on the Mach III website:

<http://www.machiii.com/Products/Tension-Control/Pneumatic-Clutch/SensiFlex-Foot-Mount-Clutches.asp>

Please contact Mach III to obtain parts list drawings.



**These products include rotating equipment and should be guarded according to OSHA requirements and other Federal, State and local regulations. It is the responsibility of the user to provide the necessary guarding.**

© Mach III Clutch, Inc. All Rights Reserved

**Reference Diagram:**

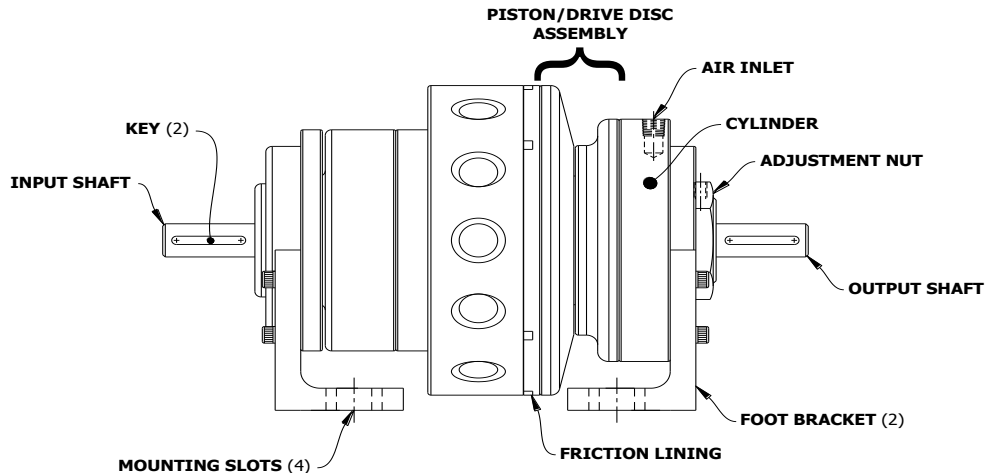

**\*\*IMPORTANT\*\***

The gap between the friction and drive surface is factory set between 0.010 and 0.020 Inch. This is the ideal clearance for proper performance. Increasing this gap may result in air leaks and damage to the diaphragm actuator. Decreasing this gap prevents full disengagement of the clutch.

**I. Installation**

**A. MOUNTING**

SensiFlex® Foot Mounted clutches are designed to deliver long, maintenance free service. The clutch has a designated input and output shaft (please refer to diagram above). Thermal horse-power ratings are only valid if the clutch is oriented in this manner.

To achieve the smoothest performance and maximum bearing life, care should be taken during installation to ensure accurate alignment.

1. The mounting surface for the clutch foot brackets must be flat.
2. The (4) mounting slots are provided to allow some axial adjustment. For best results, apply air to the clutch before tightening the (4) mounting bolts to help maintain proper positioning of the feet.

**B. AIR LINE CONNECTION**

Air supply should be both filtered and regulated. Contamination in the air supply will cause damage to the clutch, particularly to the diaphragm actuator. Connect a flexible airline to the air inlet using a thread sealing compound. **Do not use rigid piping.** Cycle the clutch with the machine off to assure engagement and release.

**II. Operation**

Torque is proportional to air pressure. SensiFlex® clutches are designed for use in slip applications, typically to maintain tension on a web during rewinding or a similar tension control application. Mach III Clutch, Inc. should *always* be consulted to assist with selection of a SensiFlex® Clutch to assure that required tension can be maintained while dissipating the heat caused by constant slip.



### III. Routine Maintenance

Friction discs are a “wear” item and in a constant slip application, periodic replacement of the friction disc will be necessary. The frequency of disc replacement varies with each application. Screws are used to mount the friction disc on the drive disc. Wear of the friction disc should be monitored so that it can be replaced prior to the point at which the heads of the mounting screws would make contact with the input sleeve. See chart below for replacement point recommendations.

#### Friction Disc Replacement Recommendations

| Product        | Original Thickness of Friction Disc | Replace When Worn To A Thickness of |
|----------------|-------------------------------------|-------------------------------------|
| 38FM/38FM-ULOW | 3/16 Inch                           | 9/64 Inch                           |
| 58FM/58FM-ULOW | 1/4 Inch                            | 1/8 Inch                            |
| 78FM/78FM-ULOW | 5/16 Inch                           | 3/16 Inch                           |
| 98FM/98FM-ULOW | 7/16 Inch                           | 5/16 Inch                           |

#### Repair Parts & Services

| Kits Available | Contents   | Part Numbers                               |
|----------------|--|--|
| Facing Kit     | Friction Disc & Mounting Screws                      | 38FM-FCGK, 38FM-ULOW-FCGK, 58FM-FCGK, Etc. |
| Repair Kit     | Friction Disc, Mounting Screws, Spring(s), Diaphragm | 38FM-RPRK, 38FM-ULOW-RPRK, 58FM-RPRK, Etc. |

For parts not included in the kits, please contact Mach III Clutch, Inc. or your distributor. Factory repair is also available. A return materials authorization (RMA) number must be obtained prior to sending any unit in for repair. Mach III Clutch is not responsible for products returned without authorization.

### IV. Repair Procedure

| <b>Tools Needed</b>   | <b>Compounds Required</b>                          |
|---|--|
| Hex wrench set<br>Retainer (snap) ring pliers<br>Flat head screw driver<br>Scraper (if replacing bearings)<br>0.010 Inch feeler gauge | Grease<br>O-Ring lubricant<br>Anti-Seize Lubricant |

#### A. Clutch Removal

Clutch can be removed by two methods:

1. Remove the four (4) socket head cap screws from each of the foot brackets and lift only the clutch from the foot mounts.
2. Remove the four bolts which affix the foot brackets to the mounting plate and remove the entire clutch assembly. The foot brackets may be removed or left in place for the remainder of the repair process - whichever allows easier handling.

## **B. Disassembly and Friction Disc Replacement**

Loosen set screw in adjustment nut and remove nut from drive hub. The bearing under the nut is a sliding fit and the cylinder/piston/disc subassembly should slide off of the shaft. If not, use a soft-faced hammer to tap loose. If installing only a facing kit, use caution to avoid losing the wave spring (38FM, 58FM & 78FM) or six coil springs (98FM & 1180FM) located between the drive disc and drive hub when separating. The friction disc is attached to the drive disc with six (6) flathead brass screws. Remove the screws and worn friction disc. Mount new friction disc by snugging all screws first then tighten firmly using an alternating sequence. Do not over-tighten. Inspect the mating surface of the cast iron sleeve input member. Grooves in the surface would indicate that the friction disc should have been replaced sooner and the heads of the mounting screws have made contact. This surface must be free from grooves, burrs and foreign materials for proper clutch operation. If damage is pronounced, please contact Mach III Clutch or your distributor regarding the sleeve replacement procedure. In addition, clutch should be inspected for discoloration (turning blue). If discoloration is present, it is possible the unit is being operated beyond its capacity and Mach III Clutch should be contacted for assistance.

## **C. Diaphragm and/or Bearing Replacement**

*Diaphragm replacement should rarely be necessary if the air supply is regulated and free of contamination and if the gap between the friction and drive disc is properly set. Care should be taken when mounting the clutch to insure maximum bearing life.*

### **1. Diaphragm Replacement**

Separate the air cylinder and piston by pulling apart taking care not to bend pins. Pinch the diaphragm and pull from the grooves which retain it. Make sure that the retaining grooves and surface underneath the diaphragm are clean & free from debris. Lightly lubricate the new diaphragm (if replacement is necessary) with an O-ring lubricant such as Dow Corning® #4. Install with the lips located on the ID and OD of the diaphragm facing downward. Press the lips into the grooves by applying pressure while gliding a finger along each perimeter of the diaphragm and then assure that the lips are fully seated by running your thumb across the surface of the diaphragm in a clockwise motion several times.

### **2. Bearing Inspection & Replacement**

Check bearings for external damage (missing seal, etc.). Make sure the bearings rotate freely and smoothly by hand. If bearing replacement is necessary, remove retainer ring (at the bearing OD). The bearing should be removed from the component using an arbor press. New bearing should be pressed back into the cylinder and outer retainer ring must next be replaced.

If new bearing was not installed, gently scrape away any Loctite® residue from the inside diameter of the bearing in the air cylinder and assure that surface is clean.

## **D. REASSEMBLY**

1. Reconnect the air cylinder and piston/disc assembly.
2. Apply a thin coat of grease (such as Molykote® G-N Metal Assembly Paste) to the hex drive surface of the drive hub.
3. **If reassembling the 38, 58 or 78FM:**  
Place the wave spring over the drive hub where it rests on top of the hex portion (use new spring if installing a repair kit). Aligning the hex of the drive hub and milled hex in the drive disc, lower the cylinder/piston/disc subassembly over the drive hub. Skip to step 5.



4. **If reassembling the 98FM or 118FM:**

Place the cylinder/piston/disc subassembly with the friction disc facing upward and replace the the six (6) coil springs in the milled pockets in the drive disc (use new springs if installing a repair kit). The remainder of the clutch assembly, including the drive hub should be lifted, inverted and inserted in through the center of the cylinder/piston subassembly. Align the hex of the drive hub and milled hex in the drive disc and lift the subassembly up to meet the mating surface of the sleeve input member. Hold clutch “halves” together and invert so that the cylinder is facing upward.

5. Place the adjustment nut on the threads and tighten to a point where a 0.010 - 0.020 gap remains between friction lining and sleeve input member. It is recommended that a 0.010 feeler gauge be used. Sleeve input member should turn freely after reassembly. If you can feel contact between the friction and drive surface when rotating, loosen adjustment nut just enough to provide clearance. Tighten set screw in adjustment nut snugly when proper clearance has been achieved.
6. See “Installation” section on Page 2 of these instructions for the proper procedure for re-installing the clutch.

Technical assistance is available by contacting Mach III Clutch, Inc.

Mach III Product Warranty

<http://www.machiii.com/Resources/Warranty-Info.asp>

Mach III Clutch, Inc.

101 Cummings Drive • Walton, KY 41094

Toll free 866.291.0849 • International 859.291.0849 • Fax 859.655.8362

[info@machiii.com](mailto:info@machiii.com) • [engineering@machiii.com](mailto:engineering@machiii.com) • [www.machiii.com](http://www.machiii.com)