

Installation & Maintenance Manual

COMBINATION AIR ENGAGED FRICTION CLUTCH- SPRING ENGAGED FRICTION BRAKES STOP & START THE SHAFT INTEGRAL DOUBLE-SINGLE SPROCKET



Catalog Products:

[X3D2H-STH](#), [X3E2H-STH](#),
[X3F2H-STH](#), [X3G2H-STH](#)
[X4D2H-STH](#), [X4E2H-STH](#),
[X4F2H-STH](#), [X4G2H-STH](#)
[X5F2H-STH](#), [X5G2H-STH](#), [X5H2H-STH](#)
[X6G2G-STH](#), [X6H2G-STH](#), [X6J2G-STH](#)

*And non-catalog variations
of this clutch-brake design.*

CLICK on product numbers above to obtain
the product detail sheet which includes
dimensional data helpful during installation.

Mach III Technical Support

Toll Free: 866-291-0849
International: 001-859-291-0849
Email: engineering@machiii.com
www.machiii.com

Detail sheets and 3D models are available on the Mach III website:
<http://www.machiii.com/Products/Clutch-Brakes/Stop-Start-Shaft-Clutch-Brakes-Integral-Double-Single-Sprocket.asp>

Please contact Mach III to obtain assembly and parts list drawings.



These products include rotating equipment and should be guarded according to OSHA requirements and other Federal, State and local regulations. It is the responsibility of the user to provide the necessary guarding.



I. New Clutch-Brake Torque

New clutch or brake torque is approximately 40% less than rated design torque until the friction and drive discs are worn in (lapped, burnished). The length of time for wear-in to occur depends upon the application.

II. Clutch-Brake Installation

A. SHAFT PREPARATION & MOUNTING

Mach III Clutch products are bored to fit a precision plug gauge for the specified bore size and should slide fit the mating shaft. Make certain that the shaft is free of burrs or nicks. It may be necessary to file or sand the shaft to assure a slide fit. **Never hammer the clutch-brake onto the shaft.** Hammering on the clutch-brake may cause evident damage or subtle injury that will shorten the wear life of the unit, and will void the warranty.

- (1) Apply the anti-seize (E-Z Break[®]) lubricant from the packet provided, or equivalent, to the shaft.
- (2) Insert key (customer supplied) onto the shaft.
- (3) Slide clutch-brake over key on the shaft, align the sprocket or pulley.
- (4) Tighten set screws to secure the clutch to the shaft.

B. AIR LINE CONNECTION

Refer to the dimensional spec sheet for NPT size to obtain correct fitting. Install fitting using a thread sealing compound to prevent air leakage. Connect a flexible air line to the fitting. **Do not use rigid piping.** Air supply should be both filtered and regulated. Contamination in the air supply may damage the clutch-brake.

C. ANTI-ROTATION (REACTION) ARM CONNECTION

The air cylinder portion of a Mach III through shaft style clutch is designed to remain stationary. Due to friction in the bearing housed in the air cylinder, this member will rotate unless an anti-rotation arm (a.k.a. reaction arm) is installed. A threaded hole is provided in the cylinder for the installation of this arm. Please refer to Mach III's *Anti-Rotation (Reaction) Arm Installation Instructions* document for illustrations of proper mounting. This document is available from the Mach III website: <http://www.machiii.com/pdf/ReactionArmInstallation.pdf> or by calling Mach III to have a copy sent by email or fax.

Note that in all cases, the machine frame or bracket should not be tight against the housing of the clutch as contact may impede piston movement and will shorten bearing life.

D. FINAL INSPECTION & TESTING

Check alignment of the sprockets. Cycle the clutch-brake with the machine off to check for air leaks and to ensure proper engagement and release. After a short run, check set screws and alignment.

III. Clutch-Brake Operation

The maximum operating pressure should not exceed 80 PSI. Operation at pressures greater than that required for proper function will decrease the life of the bearings.

Special Note Regarding Friction Disc Contamination:

The friction material used in this product will absorb oil, water, chemicals and other contaminants. Depending on the type of contamination, clutch or brake may either seize up entirely or lose torque capacity. If friction discs become contaminated, they should be replaced. See repair kit ordering information below.

IV. Routine Maintenance

When installed and operated according to the preceding guidelines, Mach III Clutch products should require little or no routine maintenance. A repair kit is available which contains all parts subject to typical wear: friction discs, springs and O-rings.

V. Parts diagram

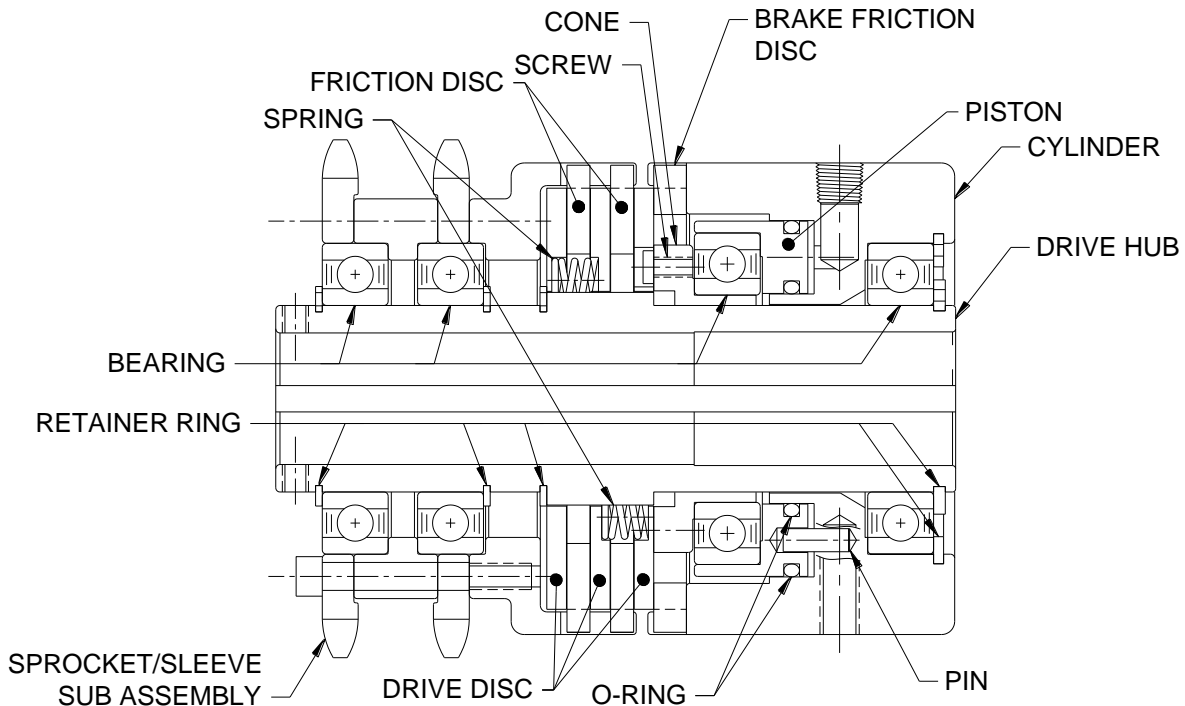

Repair Kit:	Part number = Clutch-Brake Product Number + “-RPRK” (e.g. X3D2H-STH-RPRK).
Additional Parts:	Contact Mach III to obtain a complete listing of additional parts kits available for your specific clutch. Please reference product number when calling or e-mailing.
Repair services:	Factory repair is available. A return materials authorization (RMA) number must be obtained prior to sending any unit in for repair.

VI. Repair Kit Installation Procedure

<p>Tools Required</p> <ul style="list-style-type: none"> Hex Wrench Set Rubber Mallet or similar soft face hammer Retainer (snap) Ring Pliers Scraper 	<p>Compounds Required</p> <ul style="list-style-type: none"> Grease O-ring Lubricant Loctite® #609 Retaining Compound Anti-Seize Lubricant (for re-installation)
--	---

A. CLUTCH & BRAKE FRICTION DISC & SPRING REPLACEMENT

- (1) Remove clutch-brake from shaft and place in vertical position with sleeve end facing upward.
- (2) Remove retainer ring.
- (3) Remove sprocket/sleeve sub-assembly from drive hub. The sub-assembly's bearings are a slide fit on the drive hub and are affixed to the drive hub with a thin coating of Loctite[®]. You may need to strike the hub, or an object inserted in the hub with a rubber mallet or similar soft face hammer, while pulling the sleeve upwards to break the Loctite[®] seal.
- (4) Two remaining retainer rings should now be accessible. Remove the first retainer ring.
- (5) **The last retainer ring is under pressure from the springs.** It may be necessary to use an arbor press to compress the springs to remove this last retainer ring.
- (6) Remove the drive discs, springs and friction discs.

CLUTCH & BRAKE FRICTION DISC & SPRING REPLACEMENT CONTINUED:

- (7) Drive discs should be clean, dry and free of burrs or nicks.
- (8) Assure that drive discs move freely on the drive hub and that the lugs of the friction discs move freely in the drive slots of the sleeve.
- (9) Reassemble drive & friction disc section according to reference drawing using new friction discs, springs and steel drive discs as necessary. Note that the first drive disc contains a milled hole. **It is important that this disc is replaced first during reassembly to line up with the screw in the cone.** After installing remaining friction discs, drive discs and springs it may be necessary to use an arbor press to compress the springs to replace retainer ring.
- (10) Replace sprocket/sleeve assembly and retainer rings according to reference drawing.
- (11) If cylinder is to be disassembled omit steps 9 & 10.

B. CYLINDER DISASSEMBLY

- (1) Place clutch-brake in vertical position with cylinder end facing upward.
- (2) Remove retainer ring from drive hub.
- (3) Remove air cylinder sub-assembly consisting of the piston, bearing & cone from drive hub. The air cylinder bearing is a slide fit on the drive hub and is affixed to the drive hub with a thin coating of Loctite[®]. You may need to strike the hub, or an object inserted in the hub with a rubber mallet or similar soft face hammer, while pulling the cylinder upwards to break the Loctite[®] seal.

C. O-RING & BRAKE FRICTION DISC REPLACEMENT

- (1) Separate cylinder and piston/bearing/cone sub-assembly.
- (2) Remove & inspect O-ring seals.
- (3) Replace O-rings that have been lubricated with an O-ring lubricant such as Dow Corning[®] #4 Compound or equivalent.
- (4) A very *thin* coat of O-ring lubricant should also be applied to the inner walls of the cylinder. **Be careful not to contaminate brake friction disc with O-ring lubricant.**

D. REASSEMBLY

- (1) Replace the piston/bearing/cone sub-assembly into cylinder.
- (2) Inspect the inside diameter of the bearing in the air cylinder. If Loctite[®] residue is present, gently scrape and assure that the surface is clean.
- (3) Apply a thin coat of Loctite[®] #609 retainer compound to the inside diameter of the air cylinder bearing, then slide the air cylinder/bearing sub-assembly over the drive hub. Applying excessive Loctite[®] will make future disassembly more difficult.



- (4) Replace the retainer ring. Invert clutch-brake and seat cylinder sub-assembly firmly against retainer ring.
- (5) Replace drive discs, friction discs and springs according to “CLUTCH & BRAKE FRICTION DISC & SPRING REPLACEMENT” portion of these instructions.
- (6) Replace the sleeve. Repeat instructions 2 & 3 above regarding Loctite®.
- (7) See “CLUTCH INSTALLATION” portion of these instructions for the proper procedure for reinstalling the clutch-brake.

Technical assistance is available by contacting Mach III Clutch, Inc.

Mach III Product Warranty

<http://www.machiii.com/Resources/Warranty-Info.asp>

Mach III Clutch, Inc.

101 Cummings Drive • Walton, KY 41094

Toll free 866.291.0849 • International 859.291.0849 • Fax 859.655.8362
info@machiii.com • engineering@machiii.com • www.machiii.com