

RECOMMENDATIONS FOR ANTI-ROTATION ARM MOUNTING

The air cylinder portion of a Mach III thru-shaft style clutch or combination clutch-brake is designed to remain stationary. Due to friction in the bearing housed in the air cylinder, this member will rotate unless an anti-rotation arm (a.k.a. reaction arm) is installed. Threaded holes are provided in the cylinder for the installation of this arm. Below are illustrated examples of proper anti-rotation arm installation.

A: Clutches: Bolt Through Machine Frame

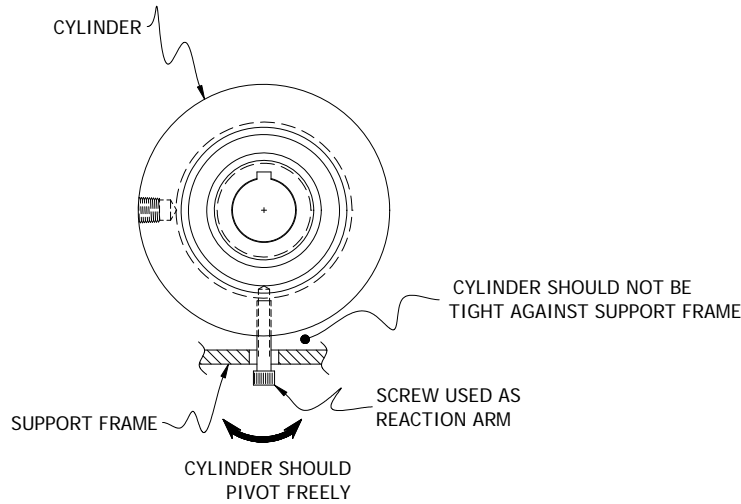

B. Clutches: Pipe Nipple Through Bracket or Machine Frame

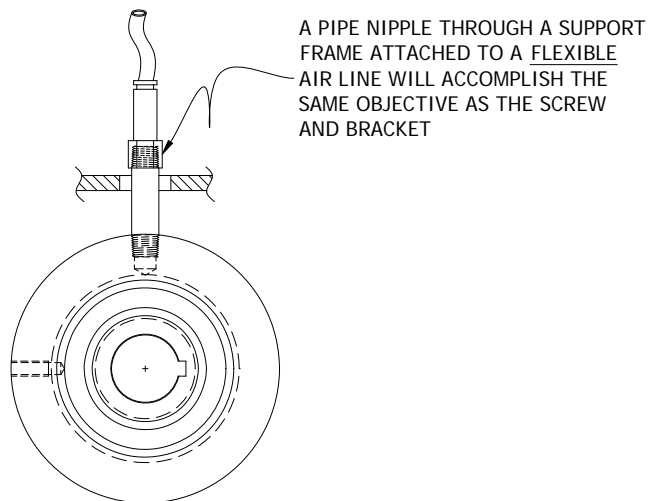

RECOMMENDATIONS FOR ANTI-ROTATION ARM MOUNTING
(continued)

C. Clutches: Bolt Through Bracket Mounted To Machine Frame

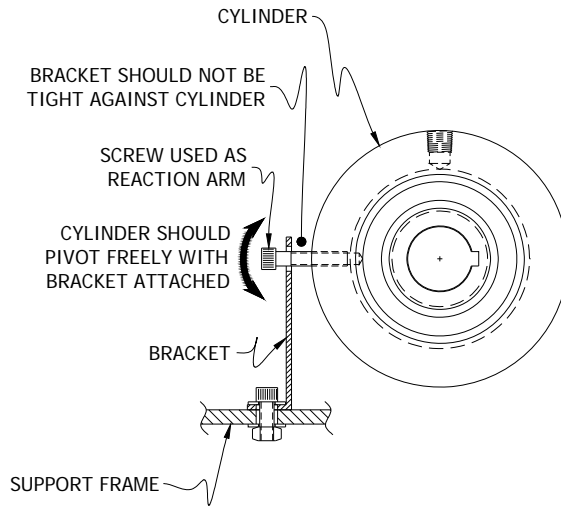

D. Combination Clutch-Brakes: One or Two Brackets Mounted To Machine Frame

In combination clutch-brake products, the anti-rotation arm performs the additional function of reacting the torque of the brake portion of the assembly. Only ONE bracket is necessary, TWO is optimal.

