

Friction Clutch – Air Applied  
 Shaft to Shaft Mount – Coupling



## M2G2R-STH

Mechanism DOES NOT support Coupling

<b>Engagement/Disengagement</b>	Air/Spring
<b>Facing Type</b>	High Coefficient
<b>Torque @ 80 PSI – Dynamic</b>	190 Pound Inches
<b>Minimum Engagement Pressure</b>	2.5 PSI
<b>Maximum Operating Pressure</b>	80 PSI
<b>Maximum RPM</b>	1,750
<b>Bore Range with Standard Keyway</b>	0.313 (7) to 0.500 (12) Inches (mm)
<b>Air Volume New</b>	0.10 Cubic Inches
<b>Air Volume Worn</b>	0.23 Cubic Inches
<b>Finish</b>	Aluminum
<b>Open or Enclosed Construction</b>	Open
<b>Shipping Weight</b>	1 Pounds

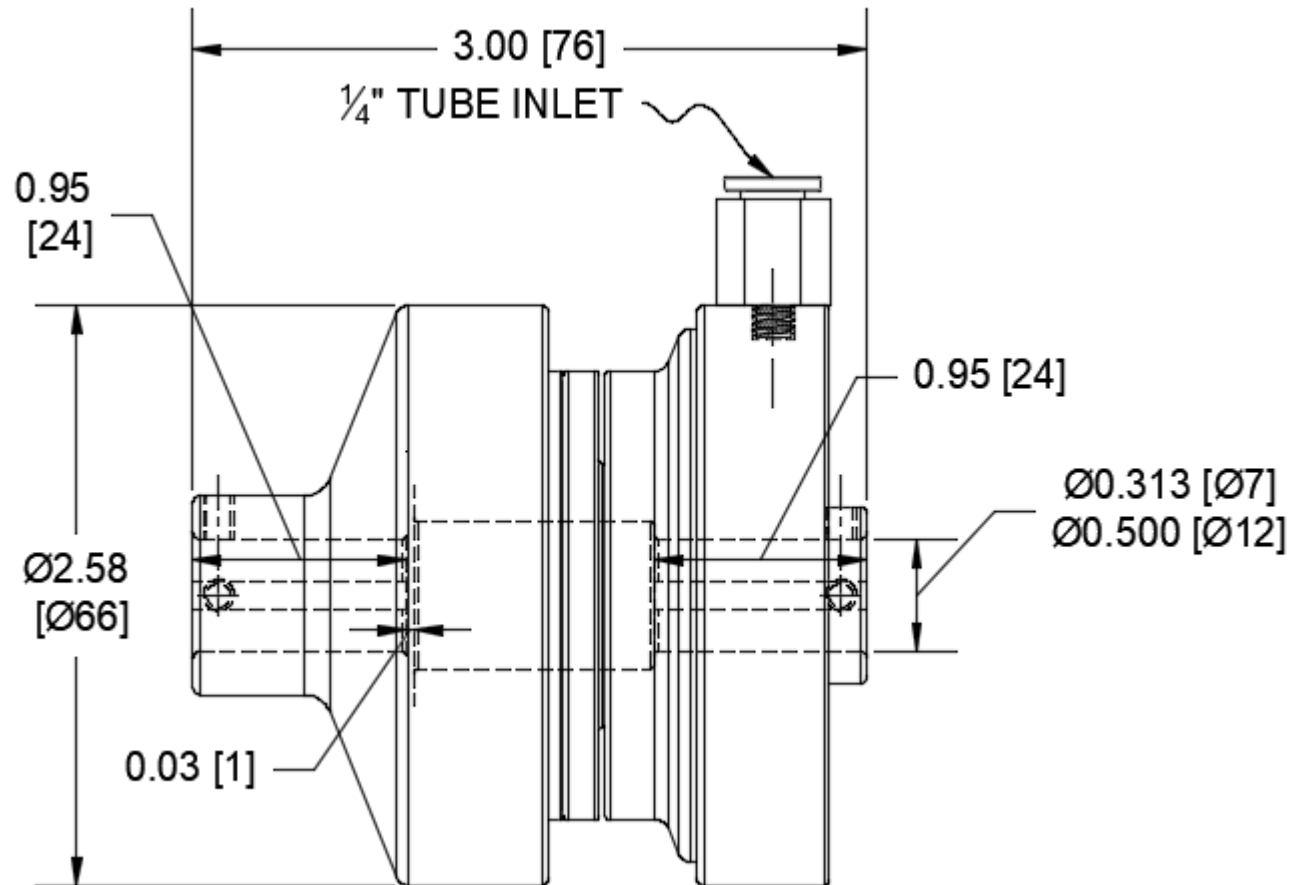

### TORQUE vs. AIR PRESSURE

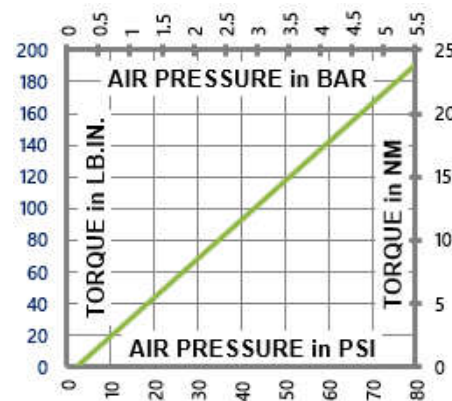

### NEW vs. BURNISHED TORQUE

New clutch or brake torque is approximately 40% less than rated design torque until the friction and drive discs are worn in (lapped, burnished). The length of time for wear-in to occur varies by application.

When calculating required torque always use a service factor of 1.5 to 2. It is not recommended to select a product for use at its maximum rated torque for continuous duty.

### PRODUCT SELECTION

Torque capacity is only one factor to consider when making a product selection. Insure that you will have right product for the job by contacting our engineering department for application review and selection assistance.



859-291-0849  
 engineering@machiii.com  
 www.machiii.com

# M2G2R-STH

## Parts Diagram

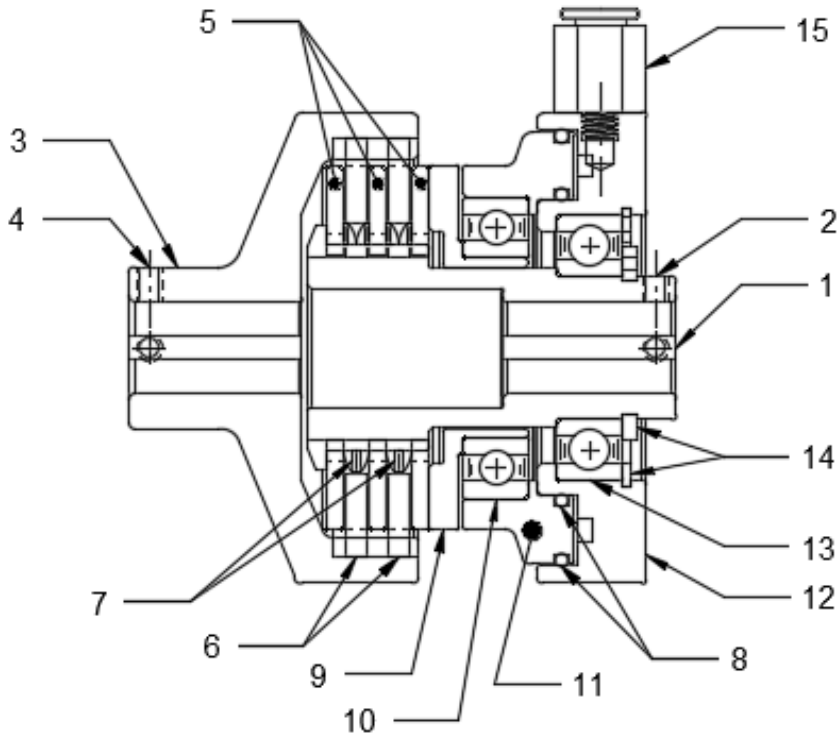

REF#	DESCRIPTION & PARTS INCLUDED	QUANTITY	KIT NUMBER
	<b>DRIVE HUB KIT</b>		<b>M2G2R-STH-HUBK</b>
1	Drive Hub	1	<i>Specify Bore Size When Ordering</i>
2	Set Screw	2	
	<b>COUPLING KIT</b>		<b>M2G2R-STH-CPLK</b>
3	Coupling	1	<i>Specify Bore Size When Ordering</i>
4	Set Screw	2	
	<b>DRIVE DISC KIT</b>		<b>C2A2R-STH-DRDK</b>
5	Drive Disc	3	
	<b>REPAIR KIT</b>		<b>M2G2R-STH-RPRK</b>
6	Friction Disc	2	
7	Wave Spring	2	
8	O-Ring	2	
	<b>PISTON KIT</b>		<b>C2A2R-STH-PSTK</b>
9	Cone	1	
10	Bearing	1	
11	Piston	1	
	<b>CYLINDER KIT</b>		<b>C2A2R-STH-CYLK</b>
12	Cylinder	1	
13	Bearing	1	
14	Retainer Ring	2	
15	AIR SEAL	1	RSEAL-034

### PARTS KITS

The *Repair Kit* contains common wear items for this product. Users are encouraged to stock one or more repair kits considering the number of units installed and the potential downtime if machinery on which the unit is installed is critical equipment. To obtain current pricing and lead time for parts kits, contact customer service.

[orders@machiii.com](mailto:orders@machiii.com)

### ADDITIONAL PRODUCT INFORMATION

Click on the links below or copy and paste into your web browser.

To view the Installation & Maintenance Manual for this product:

<http://www.machiii.com/PDF/Product-Manuals/CLUTCH MECH W COUPL AIR RD MANUAL.pdf>

For information about the application and use of this and other Mach III products:

<http://machiii.com/Application/Default.asp>



859-291-0849

[engineering@machiii.com](mailto:engineering@machiii.com)

[www.machiii.com](http://www.machiii.com)