

X4G2H-002

Combination Air Engaged Friction Clutch, Spring Engaged Friction Brake, Double-Single Sprocket Stop & Start the Shaft



Minimum Sprocket Size

Chain Size	60
Number Teeth	19

Clutch Engagement/Brake Engagement

Air/Spring

Facing Type

High Coefficient

Clutch Torque @ 80 PSI (max) – Dynamic

712 Pound Inches

Brake Torque @ Spring Pressure (fixed)

62 Pound Inches

Brake Release Pressure

20 - 25 PSI

Maximum RPM

1,750

Bore with Standard Keyway

1.250 Inches

Air Volume New

0.8 Cubic Inches

Air Volume Worn

1.3 Cubic Inches

Finish

Aluminum

Open or Enclosed Construction

Open

Shipping Weight

13 Pounds

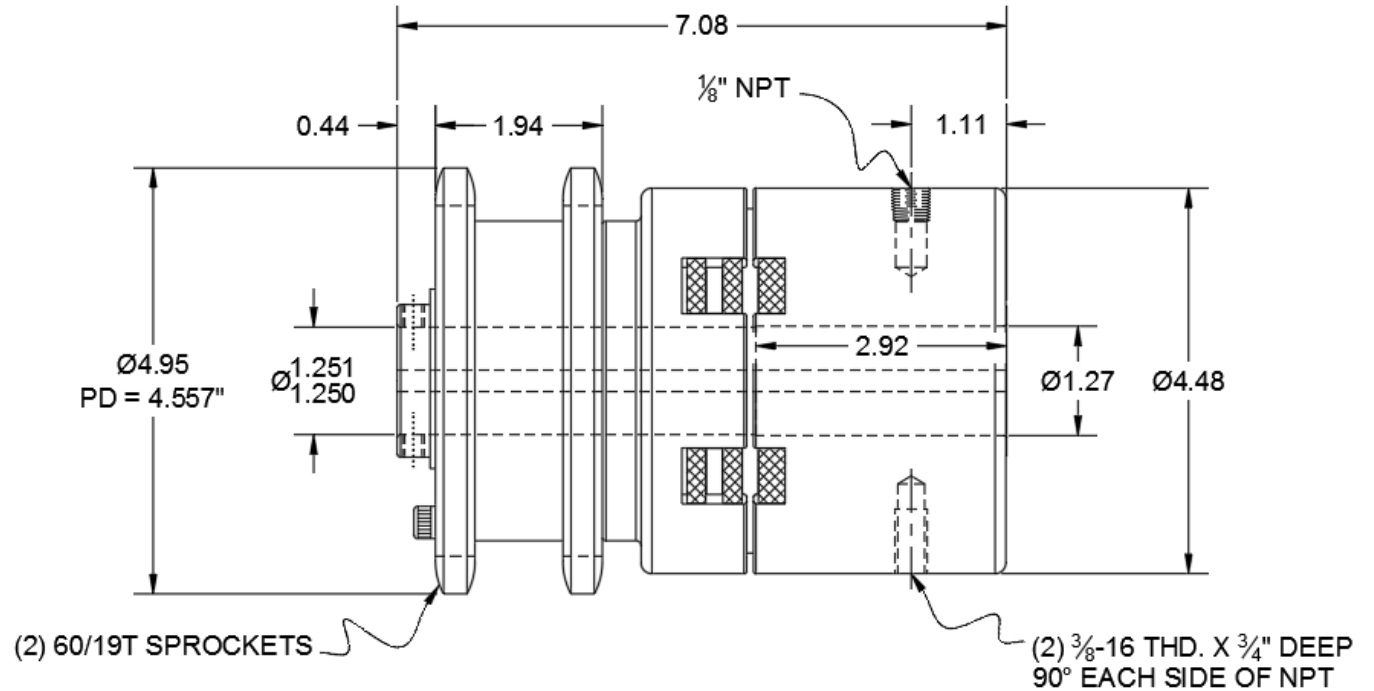

TORQUE vs. AIR PRESSURE

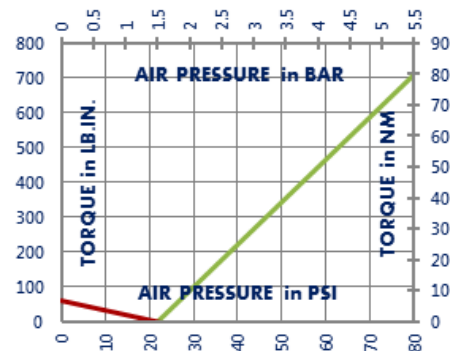

NEW vs. BURNISHED TORQUE

The torque output of a new friction brake or clutch can be up to 40% less than the published torque rating. To achieve full design torque, a unit must be cycled under load to burnish the friction surfaces. The exact number of cycles varies by application.

When calculating required torque always use a safety factor of 1.5 to 2. It is not recommended to select a product for use at its maximum rated torque for continuous duty.

PRODUCT SELECTION

Torque capacity is only one factor to consider when making a product selection. Ensure that you will have the right product for the job by contacting our engineering department for application review and selection assistance.



101 Cummings Drive
Walton, KY 41094 USA

859-291-0849

machiii.com

engineering@machiii.com

X4G2H-002

Parts Diagram

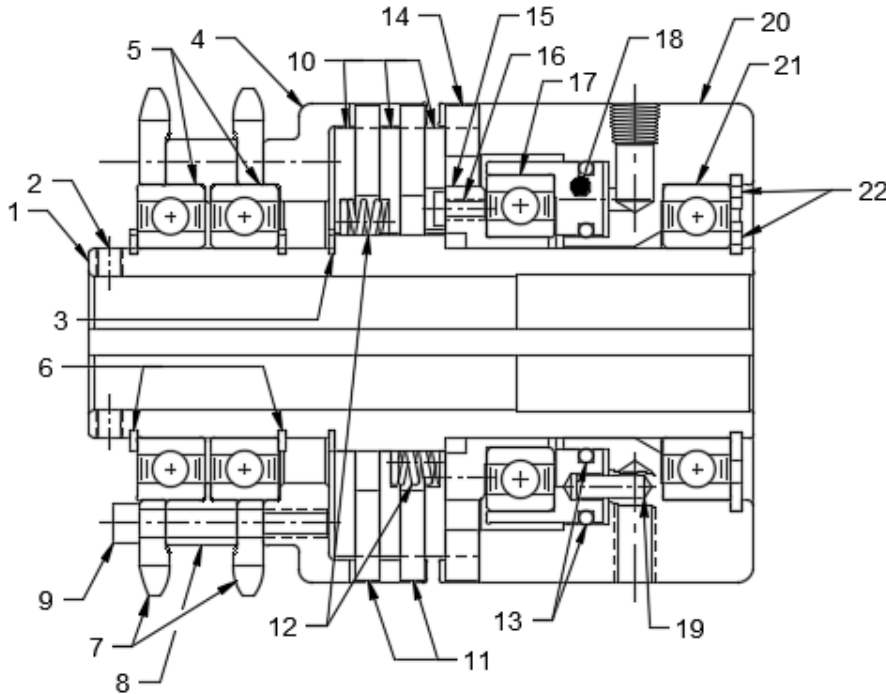

REF#	DESCRIPTION & PARTS INCLUDED	QUANTITY	KIT NUMBER
DRIVE HUB KIT			X4G2H-002-HUBK
1	Drive Hub	1	
2	Set Screw	2	
3	Retainer Ring	1	
SLEEVE KIT			X4G2H-002-SLVK
4	Sleeve	1	
5	Bearing	2	
6	Retainer Ring	2	
7	Sprocket	2	
8	Spacer	1	
9	Screw	3	
DRIVE DISC KIT			W4A2H-STH-DRDK
10	Drive Disc	3	
REPAIR KIT			X4G2H-002-RPRK
11	Friction Disc	2	
12	Spring	12	
13	O-Ring	2	
14	Brake Friction Disc	1	
PISTON KIT			X4A2H-STH-PSTK
15	Cone	1	
16	Screw	1	
17	Bearing	1	
18	Piston	1	
CYLINDER KIT			X4A2H-STH-CYLK
19	Pins	6	
20	Cylinder	1	
21	Bearing	1	
22	Retainer Ring	2	

PARTS KITS

The *Repair Kit* contains common wear items for this product. Users are encouraged to stock one or more repair kits considering the number of units installed and the potential downtime if machinery on which the unit is installed is critical equipment. To obtain current pricing and lead time for parts kits, contact customer service.

orders@machiii.com

ADDITIONAL PRODUCT INFORMATION

For illustrated guides showing how Mach III products work, selection guidelines, product manuals, and installation and use recommendations:

<https://machiii.com/resources/how-our-products-work>

For information about how to order, return policy and warranty information:

<https://machiii.com/resources/how-to-order>



859-291-0849

machiii.com

engineering@machiii.com