

# C3L2R-003

Air Applied Clutch with Integral Spool



## Engagement/Disengagement

Air/Spring

## Facing Type

High Coefficient

## Torque @ 80 PSI – Dynamic

555 Pound Inches

## Minimum Engagement Pressure

6 PSI

## Maximum Operating Pressure

80 PSI

## Maximum RPM

1,500

## Bore with Standard Keyway

1.000

## Air Volume New

0.20 Cubic Inches

## Air Volume Worn

1.30 Cubic Inches

## Finish

Aluminum

## Open or Enclosed Construction

Open

## Shipping Weight

6 Pounds

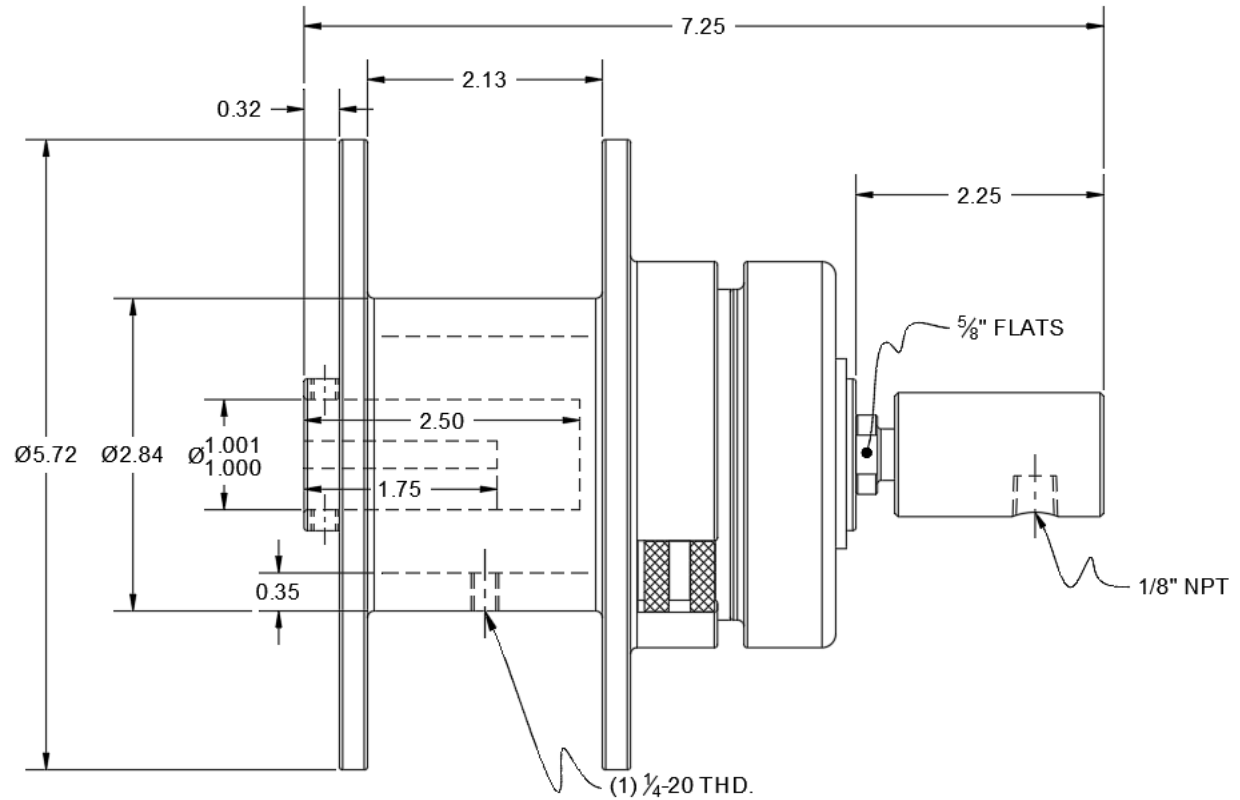

## TORQUE vs. AIR PRESSURE

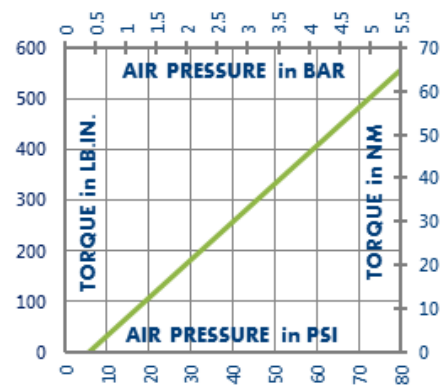

## NEW vs. BURNISHED TORQUE

The torque output of a new friction brake or clutch can be up to 40% less than the published torque rating. To achieve full design torque, a unit must be cycled under load to burnish the friction surfaces. The exact number of cycles varies by application.

When calculating required torque always use a safety factor of 1.5 to 2. It is not recommended to select a product for use at its maximum rated torque for continuous duty.

## PRODUCT SELECTION

Torque capacity is only one factor to consider when making a product selection. Ensure that you will have the right product for the job by contacting our engineering department for application review and selection assistance.



101 Cummings Drive  
Walton, KY 41094 USA

859-291-0849

[machiii.com](http://machiii.com)

[engineering@machiii.com](mailto:engineering@machiii.com)

# C3L2R-003

## Parts Diagram

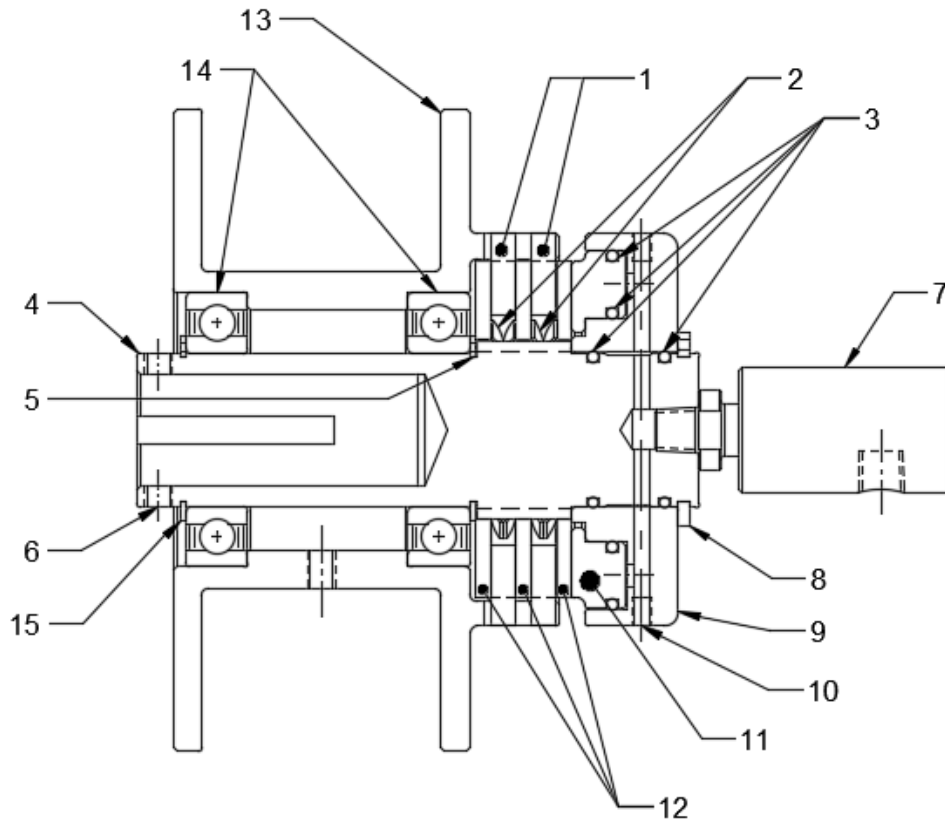

REF#	DESCRIPTION & PARTS INCLUDED	QUANTITY	KIT NUMBER
	<b>REPAIR KIT</b>		<b>C3L2R-003-RPRK</b>
1	Friction Disc	2	
2	Wave Spring	2	
3	O-Ring	4	
	<b>DRIVE HUB KIT</b>		<b>C3L2R-003-HUBK</b>
4	Drive Hub	1	
5	Retainer Ring	1	
6	Set Screw	2	
7	ROTATING SEAL	1	RSEAL-032
	<b>CYLINDER KIT</b>		<b>C3D2H-STH-CYLK</b>
8	Retainer Ring	1	
9	Cylinder	1	
10	Screw	2	
11	PISTON	1	C3D2H-STH-P004
	<b>DRIVE DISC KIT</b>		<b>C3D2R-STH-DRDK</b>
12	Drive Disc	3	
	<b>SLEEVE KIT</b>		<b>C3L2R-003-SLVK</b>
13	Sleeve	1	
14	Bearing	2	
15	Retainer Ring	1	

### PARTS KITS

The *Repair Kit* contains common wear items for this product. Users are encouraged to stock one or more repair kits considering the number of units installed and the potential downtime if machinery on which the unit is installed is critical equipment. To obtain current pricing and lead time for parts kits, contact customer service.

[orders@machiii.com](mailto:orders@machiii.com)

### ADDITIONAL PRODUCT INFORMATION

For illustrated guides showing how Mach III products work, selection guidelines, product manuals, and installation and use recommendations:

<https://machiii.com/resources/how-our-products-work>

For information about how to order, return policy and warranty information:

<https://machiii.com/resources/how-to-order>



859-291-0849

[machiii.com](http://machiii.com)

[engineering@machiii.com](mailto:engineering@machiii.com)