

B6F1Q-001

Air Engaged friction Brake
Flange Mount / Motor Frame



Engagement/Disengagement

Air/Spring

Facing Type

High Coefficient

Torque @ 80 PSI – Dynamic

1,078 Pound Inches

Minimum Engagement Pressure

4 PSI

Maximum Operating Pressure

80 PSI

Maximum RPM

1,750

Bore with Standard Keyway

46 mm

Air Volume New

0.67 Cubic Inches

Air Volume Worn

2.48 Cubic Inches

Finish

Aluminum

Open or Enclosed Construction

Enclosed

Mounting Bolt Circle

8.189 Inches

Shipping Weight

23 Pounds

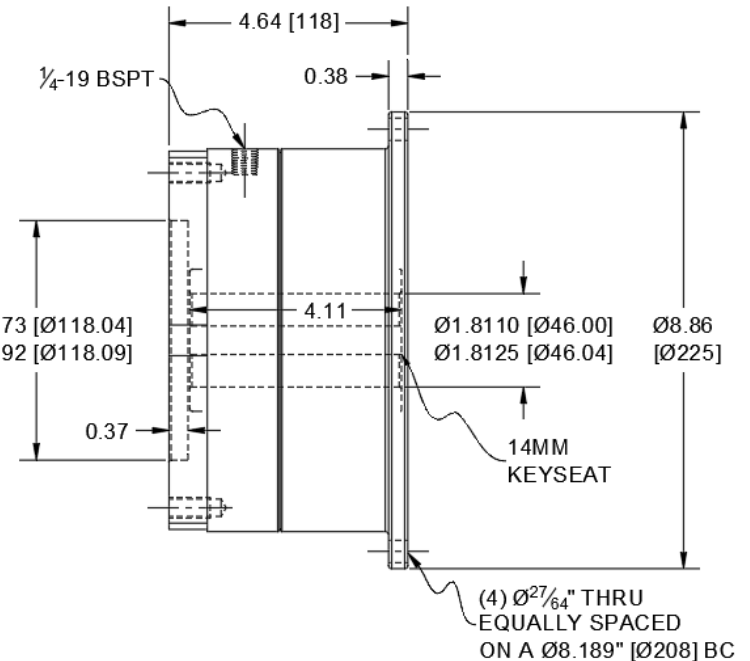
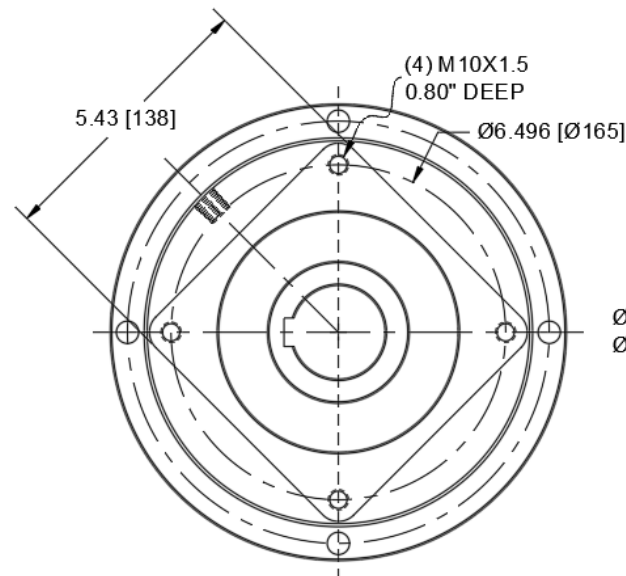

TORQUE vs. AIR PRESSURE

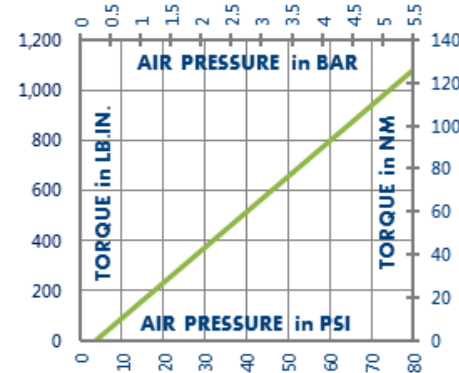

NEW vs. BURNISHED TORQUE

The torque output of a new friction brake or clutch can be up to 40% less than the published torque rating. To achieve full design torque, a unit must be cycled under load to burnish the friction surfaces. The exact number of cycles varies by application.

When calculating required torque always use a safety factor of 1.5 to 2. It is not recommended to select a product for use at its maximum rated torque for continuous duty.

PRODUCT SELECTION

Torque capacity is only one factor to consider when making a product selection. Ensure that you will have the right product for the job by contacting our engineering department for application review and selection assistance.



101 Cummings Drive
Walton, KY 41094 USA

859-291-0849

machiii.com

engineering@machiii.com

B6F1Q-001

Parts Diagram

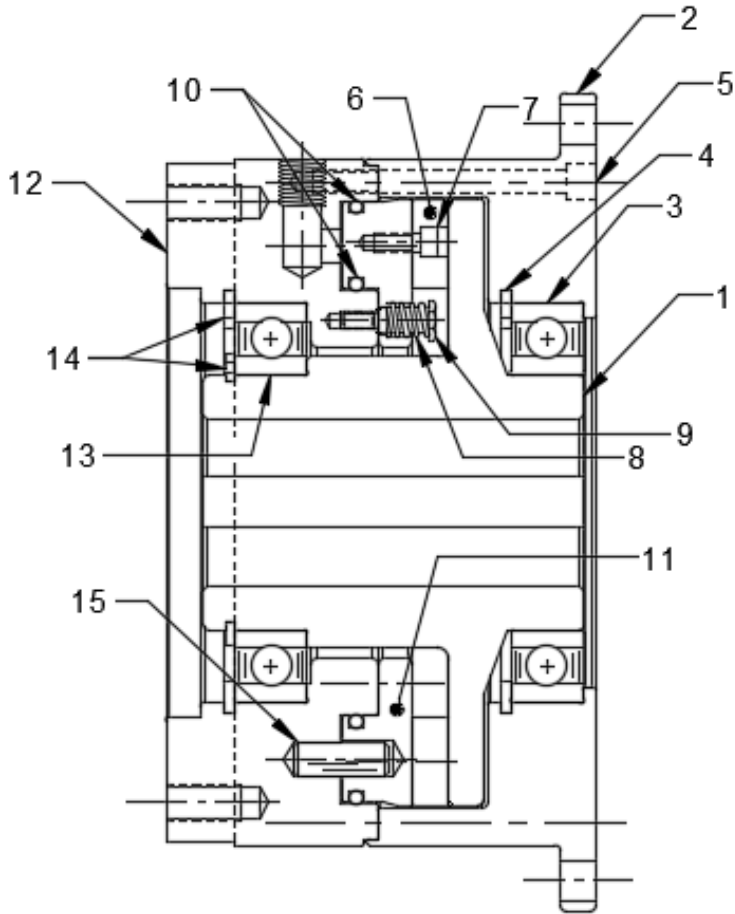

REF#	DESCRIPTION & PARTS INCLUDED	QUANTITY	KIT NUMBER
DRIVE HUB KIT			B6F1Q-001-HUBK
1	Drive Hub	1	
ADAPTER KIT			B6F1Q-001-ADPK
2	Adapter	1	
3	Bearing	1	
4	Retainer Ring	1	
5	Screw	6	
REPAIR KIT			B6F1Q-001-RPRK
6	Friction Disc	1	
7	Screw	6	
8	Coil Spring	3	
9	Stud	3	
10	O-Ring	2	
11	PISTON	1	B6F1Q-001-P004
CYLINDER KIT			B6F1Q-001-CYLK
12	Cylinder	1	
13	Bearing	1	
14	Retainer Ring	2	
15	Pin	6	

PARTS KITS

The *Repair Kit* contains common wear items for this product. Users are encouraged to stock one or more repair kits considering the number of units installed and the potential downtime if machinery on which the unit is installed is critical equipment. To obtain current pricing and lead time for parts kits, contact customer service.

orders@machiii.com

ADDITIONAL PRODUCT INFORMATION

For illustrated guides showing how Mach III products work, selection guidelines, product manuals, and installation and use recommendations:

<https://machiii.com/resources/how-our-products-work>

For information about how to order, return policy and warranty information:

<https://machiii.com/resources/how-to-order>



859-291-0849

machiii.com

engineering@machiii.com